

## 7.4

# Solving Problems Involving Prisms and Cylinders

## Focus on...

After this lesson, you will be able to...

- solve problems involving right rectangular prisms, right triangular prisms, and right cylinders

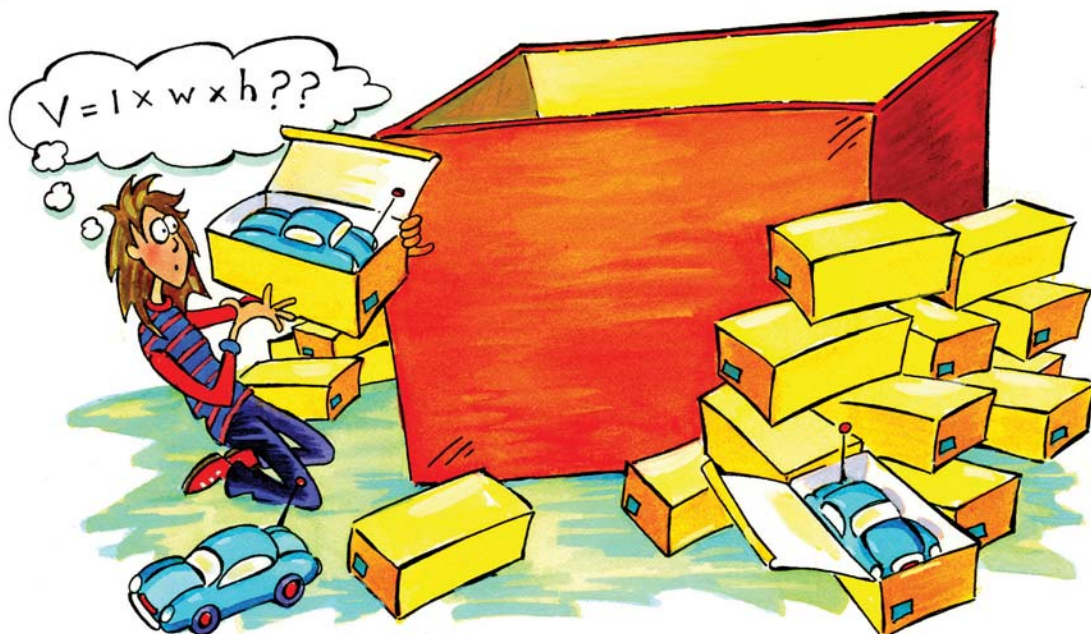

Danielle works at a toy store that sells remote control cars. She wants to fit 60 car boxes into a large crate. The car boxes have dimensions of  $50\text{ cm} \times 30\text{ cm} \times 20\text{ cm}$ . The crate has dimensions of  $140\text{ cm} \times 120\text{ cm} \times 110\text{ cm}$ . Predict whether all 60 boxes fit in the crate.

## Explore the Math

### Materials

- centimetre cubes
- centimetre grid paper



### How can you solve a problem involving volume?

1. Calculate the volume of one car box and the volume of the crate described above.
2. Estimate the number of boxes that could fit into the crate.
3. Model the problem to determine how many boxes you can fit in the crate.



4. a) Share your model with your classmates. What was the greatest number of boxes that fit into the crate?
- b) Could you arrange your boxes differently to improve the modelled number of boxes that would fit in the crate? Explain.

### Reflect on Your Findings

5. How did the estimated number of boxes compare with the modelled number of boxes that would fit in the crate? Explain any differences.

### Example 1: Solve a Problem Involving Right Triangular Prisms

Marcus is making a display of packages of Prism Chocolates in his candy shop. He will stack 64 packages to form a shape that is a triangular prism, using eight packages in the bottom layer. What is the volume of the display? Show your thinking.

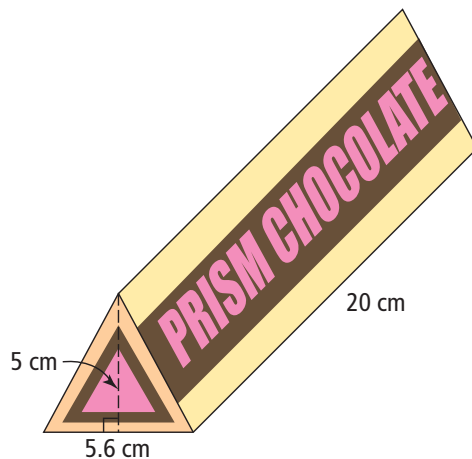

**Strategies**

**Draw a Diagram**

**Solution**

The packages are triangular prisms.

The best way to stack the packages is to place Layer 1 on the table, then invert Layer 2 in the cavities between the packages in the first layer. In order to maintain a triangular shape, Layer 3 must have the same number of packages as Layer 2.

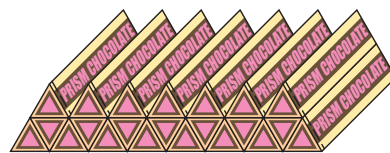

Determine the volume of one package:

Volume = (base of triangle  $\times$  height of triangle  $\div$  2)  $\times$  height of prism

$$V = (5.6 \times 5 \div 2) \times 20$$

$$V = 14 \times 20$$

$$V = 280$$

The volume of one package is 280 cm<sup>3</sup>.

The number of packages used in the display is 64.

$$\begin{aligned} \text{The volume of the display} &= 280 \times 64 \\ &= 17\,920 \end{aligned}$$

The volume of the display is 17 920 cm<sup>3</sup>.

**Example 2: Solve a Problem Involving Cylinders**

A cylinder with a radius of 0.6 m and a height of 15 m needs to be replaced with a cylinder of equal volume. However, the new cylinder has a radius of 0.5 m. How high must the new cylinder be?

**Solution**

Determine the volume of the original cylinder.

$$V = \pi \times r^2 \times h$$

$$V \approx 3.14 \times 0.6^2 \times 15 \quad \boxed{C} \quad 3.14 \times .6 \times .6 \times 15 = 16.956$$

$$V \approx 16.956$$

The original cylinder has a volume of 16.956 m<sup>3</sup>.

To determine the new height, replace all variables in the formula with values except for  $h$ .

$$V = \pi \times r^2 \times h$$

$$16.956 \approx 3.14 \times 0.5^2 \times h$$

$$16.956 \approx 0.785h \quad \text{Divide both sides of the equation by 0.785 to isolate the variable.}$$

$$\frac{16.956}{0.785} \approx \frac{0.785}{0.785} h \quad \boxed{C} = 16.956 \div .785 = 21.6$$

$$21.6 \approx h$$

The radius is now 0.5 m.  
The volume of 16.956 m<sup>3</sup>  
is the same.

The new cylinder must have a height of 21.6 m to contain the same volume as the original cylinder.

**Strategies**

**Solve an Equation**

## Show You Know

Workers must replace a cylindrical pipe with a radius of 0.4 m and a length of 12 m. The new pipe has a radius of 0.6 m. The volume must remain the same. How long must the new pipe be?

### Example 3: Solve a Problem Involving Right Prisms and Cylinders

Engineers Rob and Kyla have designed rectangular culverts to carry water under a new highway. They estimate that the distance under the highway is 45 m. Determine the volume of concrete they need to make the required number of culvert pieces. Give your answer to the next highest tenth of a cubic metre.

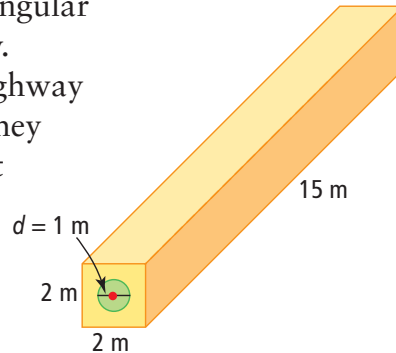

#### Solution

Draw a diagram of the culvert under the highway.

Determine the volume of the rectangular prism.

$$V = l \times w \times h$$

$$V = 2 \times 2 \times 15$$

$$V = 60$$

The volume of the rectangular prism is  $60 \text{ m}^3$ .

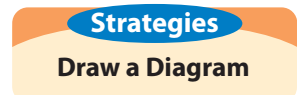
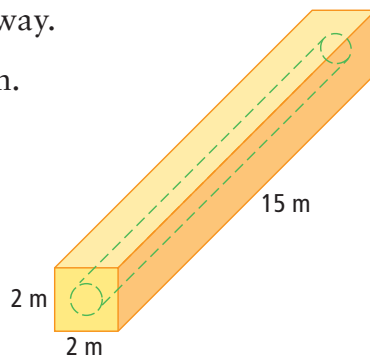

Determine the volume of the cylindrical space.

$$V = (\pi \times r^2) \times h$$

$$V \approx 3.14 \times 0.5^2 \times 15 \quad \boxed{C} \quad \boxed{3.14} \times \boxed{.5} \times \boxed{.5} \times \boxed{15} = 11.775$$

$$V \approx 11.775$$

The volume of the cylindrical space is  $11.775 \text{ m}^3$ .

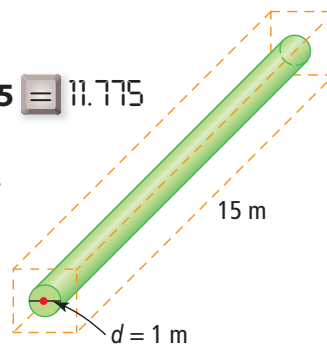

$$\begin{aligned} \text{Volume of concrete required} &= \text{volume of prism} - \text{volume of cylindrical space} \\ &\approx 60 - 11.775 \\ &\approx 48.225 \end{aligned}$$

The volume of concrete required for one culvert piece is  $48.225 \text{ m}^3$ .

Determine how many culvert pieces Rob and Kyla will need.  
 The distance under the highway is 45 m. The length of each culvert is 15 m.  
 $45 \div 15 = 3$   
 They will need three culvert pieces.

Calculate the volume of concrete required for three culvert pieces.  
 $3 \times 48.225 = 144.675$

The volume of concrete required for three culvert pieces is 144.7 m<sup>3</sup> to the nearest tenth of a cubic metre.

### Show You Know

A cube has edges 40 cm long. A cylindrical section with a radius of 15 cm is removed from the cube. What is the remaining volume of the cube, to the nearest tenth of a cubic metre?

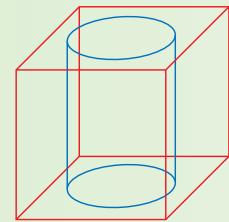

## Key Ideas

- There are different types of problems involving volumes of prisms and cylinders.
  - You may need to decide which formula to use.
  - It may help to draw a diagram.
- Some problems may involve more than one set of calculations.

### Communicate the Ideas

1. The triangular prism shown has a volume of 264 cm<sup>3</sup>. Explain how you could find its height.

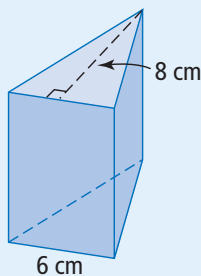

2. The object shown is hollow. Explain how you would determine its volume.

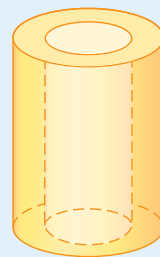

## Check Your Understanding

### Practise

For help with #3, refer to Example 1 on pages 269–270.

3. An artist has 20 triangular prisms like the one shown. He decides to use them to build a giant triangular prism with a triangular base of length 5.6 m and height 6.8 m.

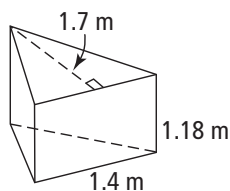

- Does he have enough small prisms?
- What is the volume of the new prism to the nearest hundredth of a metre?

For help with #4 to #6, refer to Example 2 on pages 270–271.

- Two cylinders have the same volume. The first cylinder has a diameter of 10 cm and a height of 30 cm. The second cylinder has a diameter of 8 cm. What is the height of the second cylinder, to the nearest tenth of a centimetre?
- A concrete culvert that is 10 m long has an outside diameter of 1 m and an inside diameter of 0.8 m. Determine the volume of concrete required to make the culvert, to the nearest tenth of a cubic centimetre.

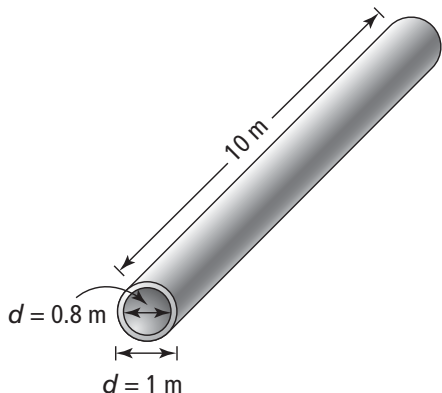

- A pipe has an outside diameter of 10 cm, an inside diameter of 8 cm, and a height of 40 cm. What is the capacity of the pipe, to the nearest tenth of a cubic centimetre?

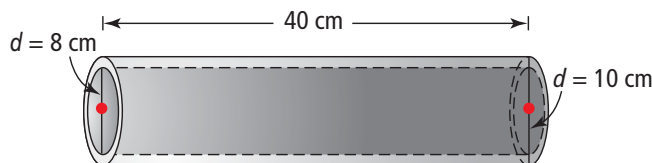

For help with #7, refer to Example 3 on pages 271–272.

- A clay planter has the shape of a right triangular prism as shown. Inside the planter is a cylindrical hole. Calculate the volume of clay needed to make the planter, to the nearest tenth of a cubic centimetre.

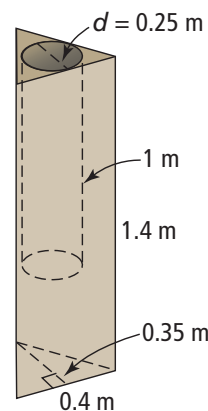

### Apply

- Manuel's company uses shipping crates with dimensions 3 m × 3 m × 7 m. He has to ship 25 000 boxes with dimensions 10 cm × 10 cm × 20 cm. Calculate whether one crate will be enough.
- Laura, an office manager, has purchased a carton that is 300 cm × 400 cm × 600 cm to store 9000 boxes of files. Each box has dimensions 30 cm × 26 cm × 10 cm. Calculate whether all of the files will fit in the carton.

10. In the cafeteria at Prairietown School, the garbage can is filled up twice every lunch hour. The garbage can is a cylinder with a radius of 25 cm and a height of 95 cm.

- Determine the volume of garbage produced each day in the cafeteria.
- Determine the volume of garbage produced in a 5-day week.
- The school's environment club wants to reduce the weekly garbage to below  $470\,000\text{ cm}^3$  by encouraging students to recycle. To reach this goal, how many times should the garbage can be filled each lunch hour?

11. A cylinder has a diameter of 80 cm and a length of 45 cm. Another cylinder has the same volume but is 80 cm long. What is the diameter of the longer cylinder?

12. A rectangular tub with dimensions  $2\text{ m} \times 1\text{ m} \times 0.5\text{ m}$  is filled with water using a pail of radius 0.1 m and height 0.35 m. How many pails of water will be required? Give your answer to the nearest whole pail.

13. A manufacturer makes right triangular prisms like the one shown for refracting light. They will be packed in boxes 12.5 cm long, 2.5 cm wide, and 22.5 cm high. How many prisms can fit in a box?

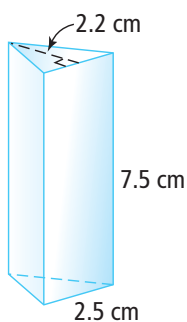

### Science Link

When a prism refracts light, it divides light into the colours of the spectrum.



14. Ted sells his homemade peanut butter for \$1.60 a jar at the local Farmers' Market. The jar is 8 cm in diameter and 10 cm high. He decides he will also sell peanut butter in jars that are 16 cm in diameter and 20 cm high. What should he charge if he uses the same price per cubic centimetre?

- A wooden block is formed in the shape shown by cutting a right rectangular solid from a larger one. What is the volume of the solid shown?
- Check your calculations by using a second method to solve the problem.

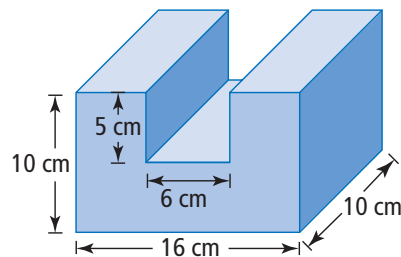

16. Fatima wants to fill a circular wading pool. She does not have a hose, so she uses a rectangular pail that she fills from a tap. The inside diameter of the pool is 120 cm and it is 25 cm deep. The inside dimensions of the pail are  $30\text{ cm} \times 22\text{ cm} \times 24\text{ cm}$  deep.



- Fatima wants to fill the pool to a depth of 18 cm. What volume of water does she have to carry?
- Each time she goes to the tap, Fatima fills the pail to a height of 20 cm. What is the volume of water in the pail?
- Calculate how many pails of water Fatima has to carry to fill the pool to a depth of 18 cm.

17. A sheet of paper that is 22 cm by 28 cm can be used to make a cylinder by rolling it in two different ways. Which way produces the larger volume? Show your work.

### Extend

18. The volume of the triangular prism shown is  $48 \text{ cm}^3$ . What is the value of the missing measurement? Show your work.

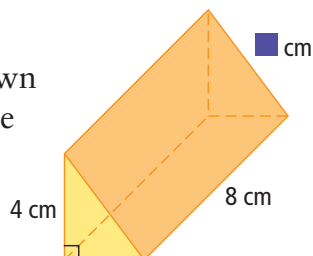

19. A cylindrical vase fits perfectly in a cube-shaped box. If the box has a volume of  $8000 \text{ cm}^3$ , what is the volume of the vase?

Volume of a cube  
 $= s \times s \times s$   
 So, 8000 is the product of three equal numbers.  
 What number is it?

20. Kevin and Jasjot plan to install a culvert that is 8 m long and holds a volume of  $40 \text{ m}^3$  of water. What diameter of culvert should they use?

21. The end of a car tunnel has the shape of a semi-circle on top of a rectangle. The tunnel is exactly 4 km long.
- Calculate the volume of air in the tunnel with no cars in it.
  - The air in a car tunnel must be exchanged frequently. If the exhaust system pumps the air out at a rate of  $10 \text{ m}^3$  per second, how long does it take to replace the stale air with fresh air in the entire tunnel? Give your answer in hours and minutes.

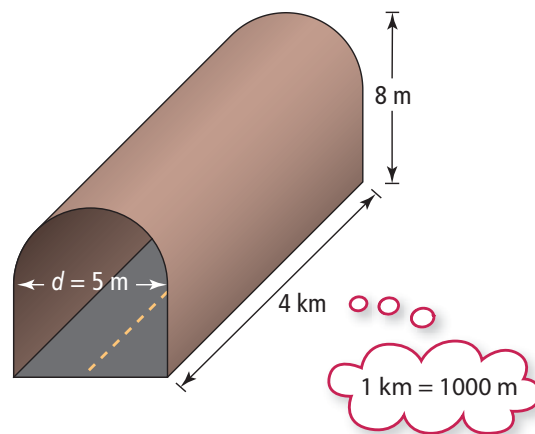

## MATH LINK

Shrub and flower planters have a variety of shapes. Some of the shapes could be connected to create a more interesting appearance.

- Design two different planters. One must be a right triangular prism.
- If the walls of the planters are 7 cm thick, determine the volume of concrete needed to construct one of your planters.
- What volume of dirt do you need to fill the planter from part b) to 2 cm from the top?

